

Fast. Accurate. Smart.

CHRONO



MASCHIO

GASPARDO

ACHIEVE THE BEST, ALWAYS.

The constant research of MASCHIO GASPARDO has led to the development of an innovative, high-speed seeding unit.

CHRONO gathers the features of accuracy, speed and efficiency in every working condition.



Terre-net

**MACHINE
OF THE YEAR 2019**



24 > 28 FEBRUARY 2019
Paris Nord Villepinte - France



CHRONO

PREMIO INNOVAZIONE
2018



NOVITÀ
Chrono

Maschio Gaspardo



polagra
PREMIERY

FIERAGRICOLA
119th International Agricultural Technology Show



The CHRONO range

The strength of MASCHIO GASPARDO is based on the satisfaction of farmers and companies from all over the world, through the offer of many different models oriented for various needs.



CHRONO 100

RIGID FRAME AND WITH
TRANSPORT TROLLEY

- Fertilizer hopper capacity:
4 x 375 l
- 12 rows with 70 cm spacing
- 18 rows with 45 cm spacing
- Transport width 3,5 m
- Tractor power requirement:
Min 200 HP

CHRONO 300

DOUBLE TELESCOPIC FRAME

- Fertilizer hopper capacity:
1 x 1200 l
- 6 rows with 70 - 75 - 80 cm spacing
- Transport width 3 m
- Tractor power requirement:
Min 120 HP



Choose the best option to optimize productivity



CHRONO 700

TRAILED FRAME WITH FRONT HYDRAULIC FOLDING

- Fertilizer hopper capacity:
1 x 1600 l
- 8 rows with 70 -75 cm spacing
- Transport width 3 m
- Tractor power requirement:
Min 130 HP

CHRONO 900

2 SECTIONS
FOLDABLE TRAILED FRAME

- Fertilizer hopper capacity:
1 x 7000 l
- Seed hopper capacity:
1 x 2000 l
- 16 rows with 70 - 75 - 80 cm
- Transport width 3,5 m
- Tractor power requirement:
Min 300 HP





PERFORMANCE

CHRONO increases the productivity by reaching a maximum working speed of over 15 km/h. Accuracy is guaranteed in every condition, and the independent vacuum systems and seed transport ensures high level performance. The pneumatic seed transport system removes the damaging effect of vibrations.



RELIABILITY

Best performance in every soil condition: direct seeding, minimum tillage or conventional.



VERSATILITY

CHRONO guarantees equal planting quality with all seed shapes and size. Not only maize and soybean, but also small seeds like sugar-beet, Canola rapeseed and sorghum or irregular shaped seeds like sunflower.

DESIGN BY



DESIGN

The CHRONO unit is the result of the cooperation between MASCHIO GASPARDO and SID Italian School of Design. It is a unique unit designed to facilitate daily operations, for instance the reduced height of the hopper simplifies the seed filling.





GO FOR ACCURACY

The unit CHRONO has been created from the necessity of a better accuracy in all working conditions. Exact seeding placement and time reduction useful for the farmer turn into better yield and profit for the farmer.



CHRONO unit: technology and accuracy at high speed

The sowing quality is the main requirement for an even growth of plants, avoiding the competition for light, water and other available resources.

The constant placement depth in every type of soil guarantees an even emergence and optimal yield.

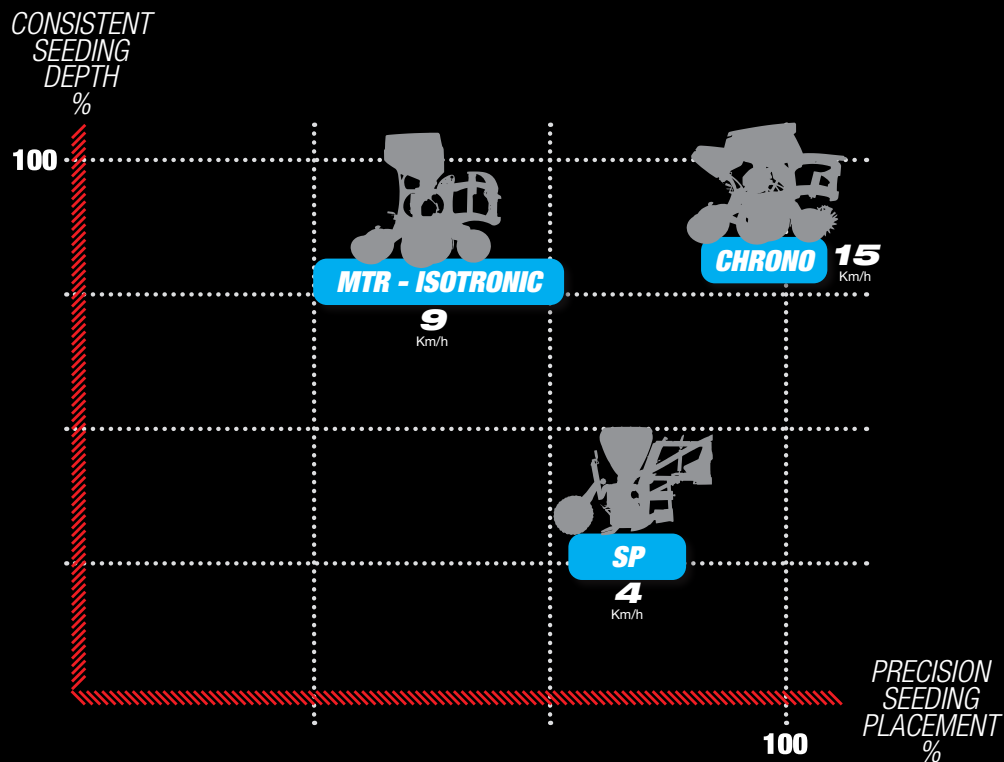

CHRONO gathers all seeding productive performances of GASPARDO units: maximum accuracy in terms of seeding depth and seed placement.

CHRONO ADVANTAGES

High speed planting offers great advantages to the farmer: higher productivity with remarkable reduction of working time and costs. These factors support a profit increase and time-saving to be dedicated to other operations. The sowing accuracy in terms of distance and depth is optimized.



COST FACTOR

With a high speed planter the productivity increase can be over 50%. Working costs and time are considerably reduced.

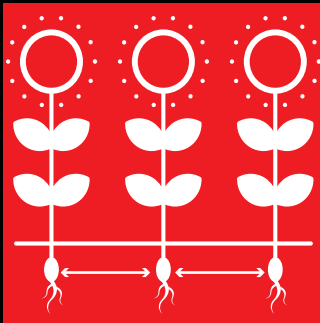

AGRONOMIC FACTOR

The productive potential of the crop is optimized from an increased accuracy of the seeding distance and an even seeding depth.



TIME FACTOR

Because of the weather trends, the window for seeding is becoming increasingly restricted. Planting at the right time allows the crop to take advantage of the most suitable moisture and temperature, reducing possible risks of losing productivity.



CHRONO

Achieve the optimum, ALWAYS!



CHRONO SYSTEM

CHRONO is fully electric and is based on a vacuum seed selection system that has always been the signature of GASPARDO precision planters. CHRONO has perfected seed singulation thanks to a micrometric seed selector.



After exiting the distributor, the seed enters the new pneumatic system and it is transported into the ground through the air flow avoiding the negative bouncing effect. The seed counter is integrated on the seed tube and controls the seed delivery, while the soft rubber and self-cleaning press wheel holds the seed in the furrow, guaranteeing the best seeding accuracy and excellent depth consistency.



It is possible to plant any type of seed without forgoing precision. According to the seed caliber, weight and shape, the seed selection vacuum and the seed transport air flow function independently. Small seeds such as rape and beet are placed perfectly, as well as those particularly shaped, like sunflower.



2 independent systems:

- The distributor's **VACUUM** is created by the fan. It suctions and maintains the seed in each hole of the seeding plate, which allows for maximum precision when choosing one seed at a time.

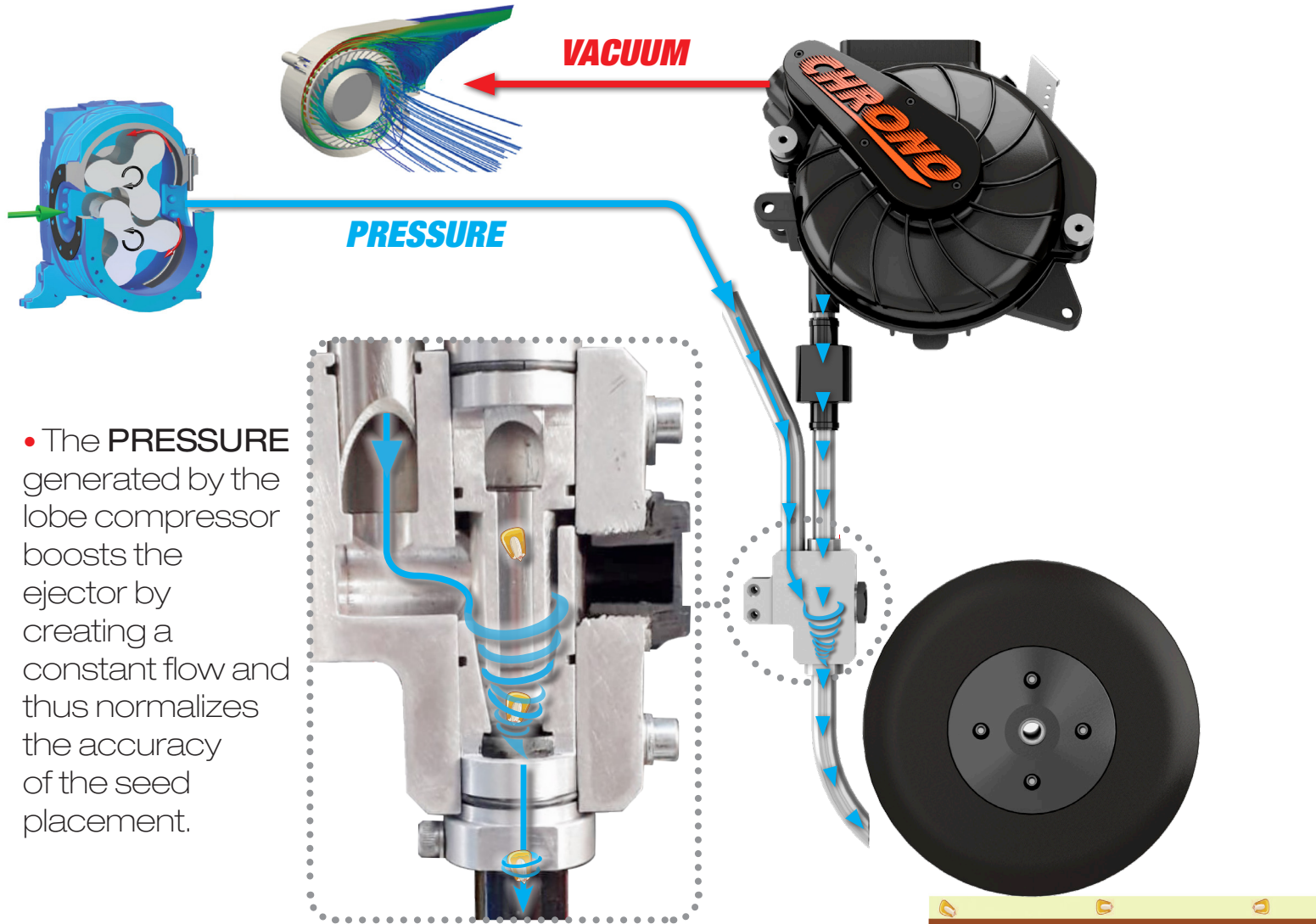

- The **PRESSURE** generated by the lobe compressor boosts the ejector by creating a constant flow and thus normalizes the accuracy of the seed placement.

The CHRONO distributor includes several novelties which are able to optimize the singulation efficiency, increasing significantly the transport system at high-speed.

ENTRY for clean air

VACUUM FLOW

DOUBLE SINGULATOR
adjustable with five newly designed teeth

SEEDING PLATE
made of high-density PVC

**ROTATING DISC
BOWL GASKET**
minimizes seed
disc friction

ALLUMINIO BODY
sturdy and durable

ALLUMINIUM COVER
newly designed and
completely detachable

CENTRAL VACUUM
throughout the cover

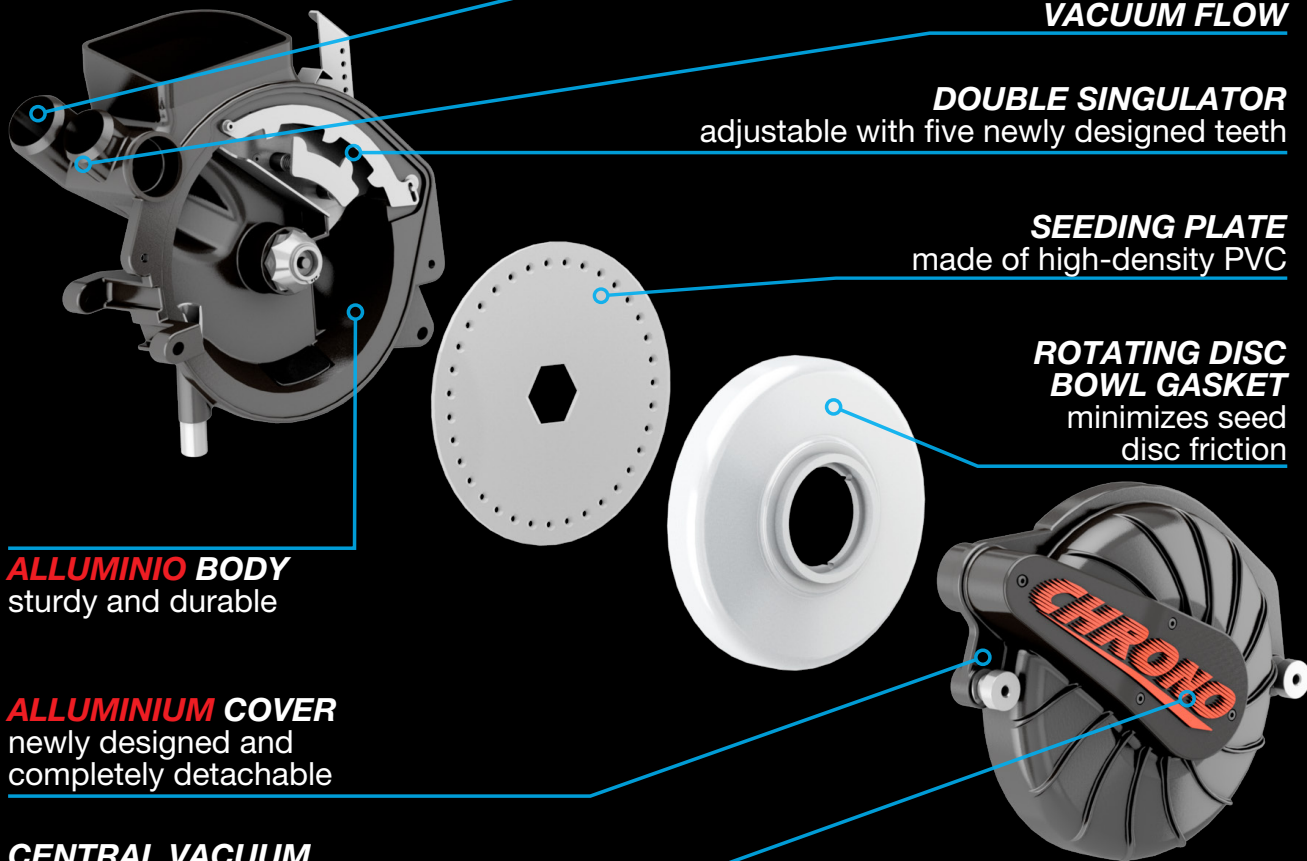

CHRONO



Thanks to the 15° angle that features the metering unit, seeds are released to the seed tube with zero friction. This feature, together with the air flow, guarantees the maximum precision.

The distributor has been designed to reduce components' wearing and to guarantee the maximum reliability in every working condition.



One electric motor for each seeding unit leads the transmission and controls the rotation of the seeding plate. After exiting the short tube, each seed is carefully blocked from the self-cleaning rubber press wheel.

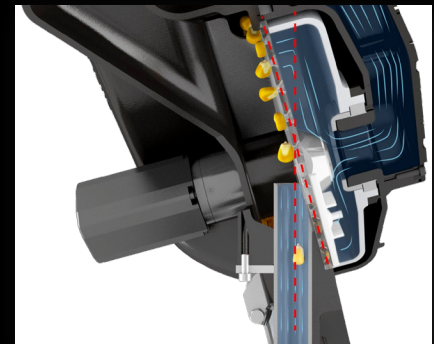

Planting unit

CHRONO is the new high speed planter of MASCHIO GASPARDO, it enriches the company's wide range of solutions for precision planting.

Thanks to its exclusively pressurized seed delivery system, the planting unit, equipped with an electrical transmission, can operate up to 15 km/h ensuring the maximum accuracy.

The innovative distribution system makes CHRONO efficient, precise in every condition and with any working speed.

Simplicity

Through the ISOBUS terminal all the planting parameters can be set easily from the tractor cab.

Versatility

Thanks to AIR SPRING the operator can control the unit down-force through the centralized adjustment directly from the ISOBUS terminal.

CHRONO excels in a wide range of conditions: from conventional tillage, to no-till. According to the type of frame, it can reach up to 300 kg of down-force on each planting unit.

Depth gauge wheels

The walking gauge wheels are independent and ensure uniform planting in all soil conditions.

The planting depth adjustment is mechanical, from 1 to 11 cm.



AIR SPRING with adjustable pressure

New seed hopper design

Innovative metering unit

Brushless electric motor

GASPARDO

*MICROGRANULATOR
hopper*

Seed depth adjustment

Independent gauge wheels

Closing wheels

A residue-free furrow

While the front trash wheel moves most of the crop residue away from the planting line, the front disc coulters cut the soil surface to facilitate the furrow opening. The latter also cuts the remaining residues to avoid them from blocking the furrow with a consequent decrease in germination rate.



The perfect contact between seed and soil

The large “V-shaped” disc coulters (\varnothing 420 mm) open the furrow for seed placement, whilst the press wheels complete the sowing operations by closing the furrow with fresh soil and pressing it for a perfect contact with the seed. Germination and crop emergence are therefore optimized.

Easy refill

The lowered height of the CHRONO planting unit (115 cm) eases the filling operation of the planter.

The new design, with an increased capacity (60 l), reduces machine downtime.

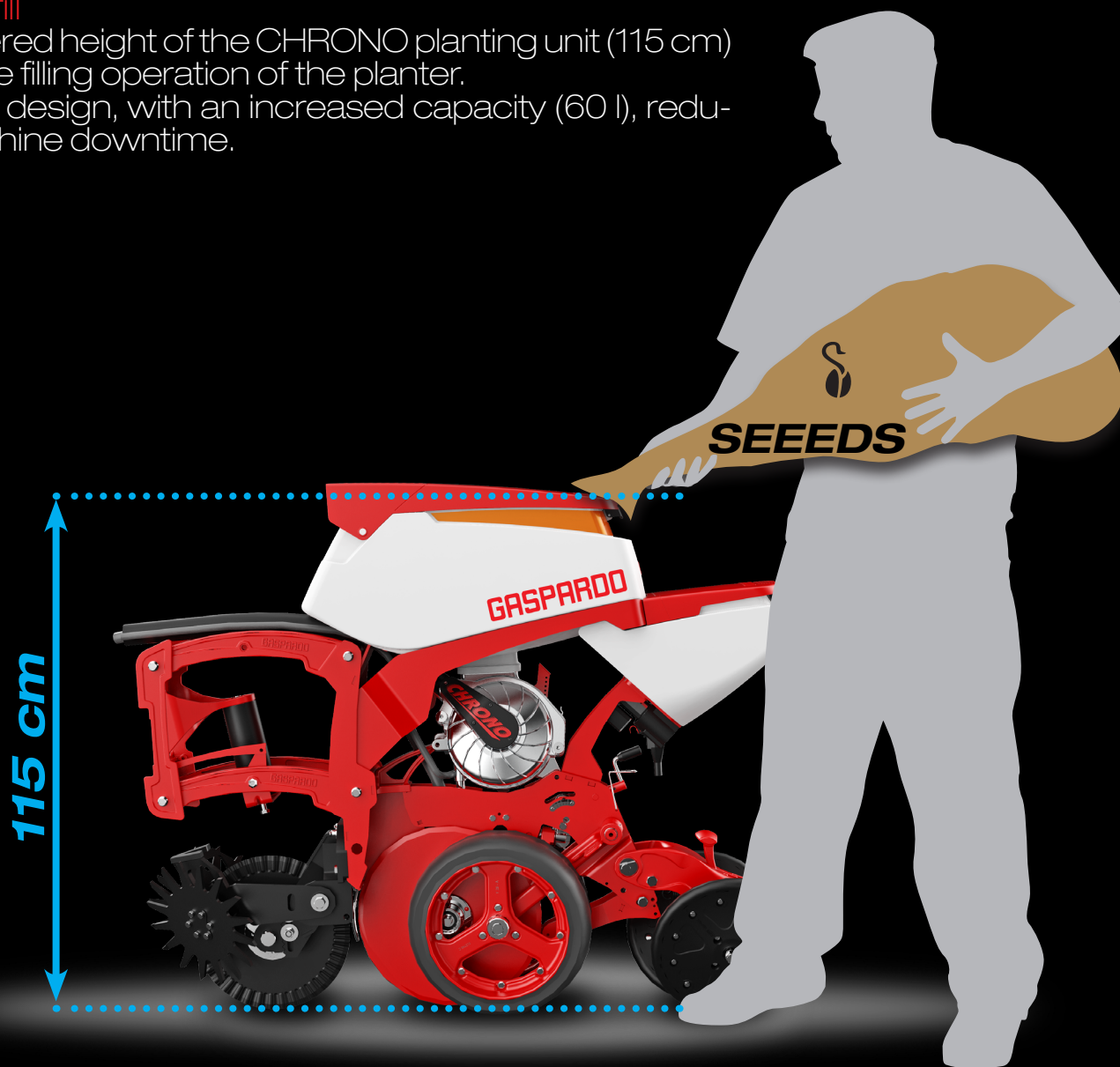

Durability

Designed with high quality components, CHRONO cuts down the periodic maintenance costs and ensures excellent long lasting performance.

One planter for all crops

CHRONO can plant different types of seed with high accuracy: from the smallest (canola, sugarbeet, soybean) to the largest (maize and sunflower).

The independent adjustments for seed vacuum singulation and pressurized-air seed delivery guarantees the best accuracy with all seed types and shapes, at any speed.

MAIZE



SUNFLOWER



SOYBEAN



CANOLA



SUGAR BEET



Nothing can stop it

With the AIR SPRING system the unit's down-force can be set directly from the ISOBUS monitor in the tractor cab.

The wide range of pressure regulations ensures a great adaptability to different soils. From tilled to no-till terrains, CHRONO is always stable.

HIGH RESIDUE SOIL CONDITION



CULTIVATED SOIL CONDITION



VARIABLE SPEED SEED TRANSPORT FLOW

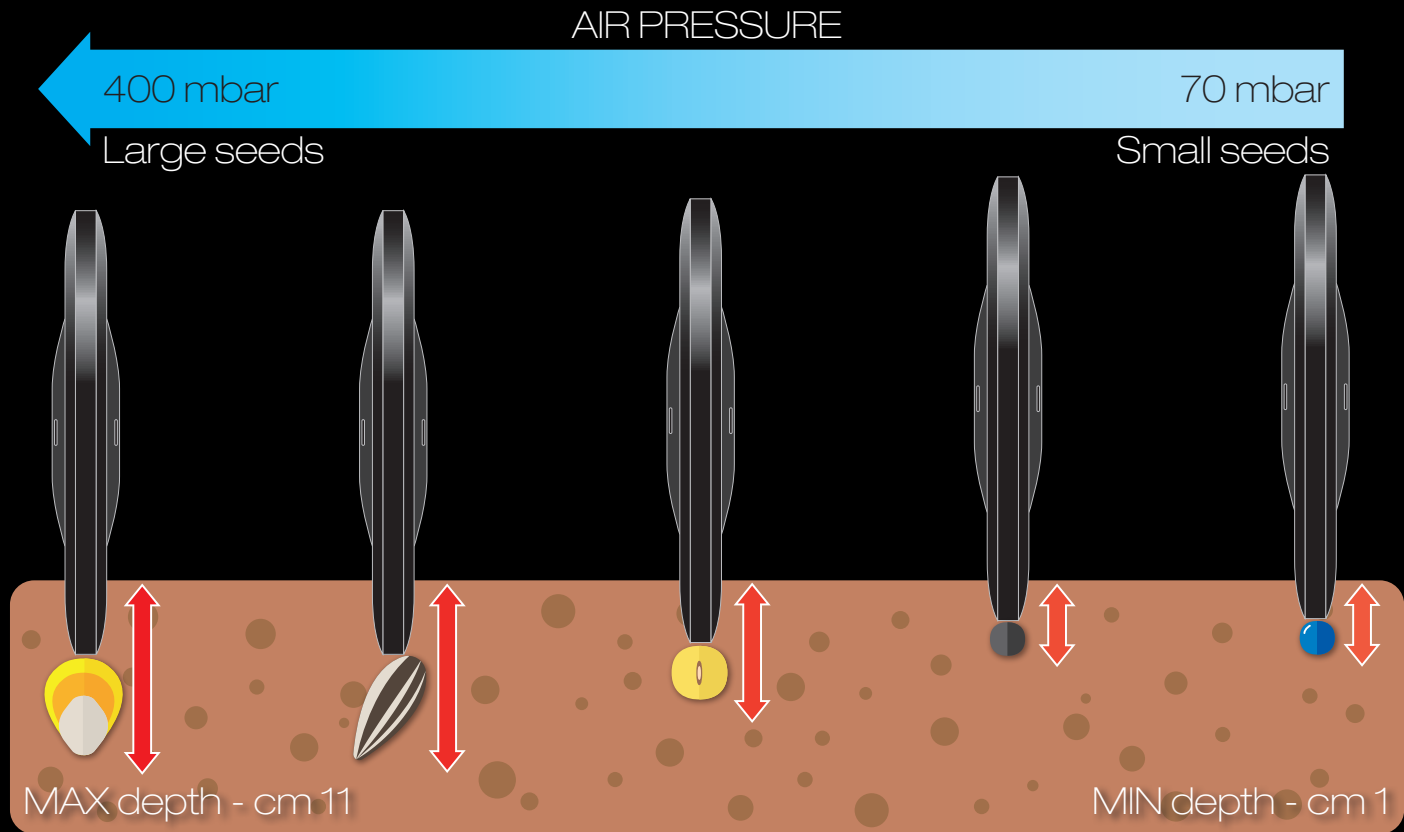

The airflow adjustment depends on:

- Size and shape of the seed
- Type of seed
- Planting depth
- Tractor speed

The press wheel has the function to perfectly stop the seed within the furrow.

CHRONO



Born to run



Variable rate

Set the plant's population according to the soil potential, increasing yield and cutting production cost.



The prescription map is a geo-referenced map which contains information and data for managing zones within a field (texture, fertility, yields, etc.)

According to the different soil potentials of the field that are often heterogeneous, the variable rate can maximize use of input and return on investment.



Once the prescription maps have been loaded into the ISOBUS monitor via USB, the tractor terminal obtains all the information regarding the rate of seed to deliver in each area.

Automatic section control

Single row sections can be automatically closed and opened, thus avoiding seeding overlapping. Through GPS signal it is possible to map the field boundaries and the zones already planted.



Each planting unit can be switched off through a BRUSHLESS electronic motor.

An independent electric motor for the microgranular application ensures a precise delivery with no waste thanks to the section control row by row.



Avoiding seeding overlapping increases yields with remarkable savings in terms of seeds. Crops have a homogeneous growth and do not compete with each other.

Long-lasting technology

Thanks to its cutting edge technology, CHRONO ensures low maintenance costs and durability, cornerstones for every farmer.

CHRONO is equipped with 12 V BRUSHLESS motors characterized by the absence of brushes; each motor, electronically controlled via the Virtual Terminal with ISOBUS protocol, allows for easy management of the planting units, cutting off the rows at any time.

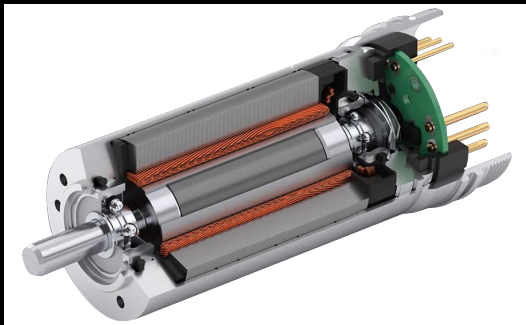

BRUSHLESS MOTOR

- + Longer lasting
- + Minimal wear of components
- + Diagnostic information through ISOBUS display
- + Zero noise or sparks
- + Hermetically sealed: no dust or humidity infiltration

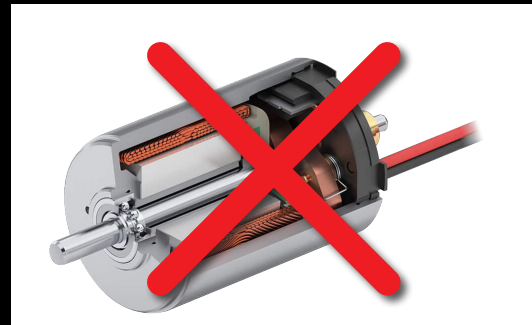

MOTORS WITH BRUSHES

- Exposed to wear
- Shorter life
- Noisy
- Higher maintenance costs
- Lower resistance to dust

Another one bites the dust!

With CHRONO there is no suction of unwanted dust or external bodies. The planting units and the volumetric lobe compressor are equipped with air filters which are positioned to ensure the aspiration of clean air, even on dry terrain.



AIR ASPIRATION
volumetric lobe compressor

AIR ASPIRATION
planting units

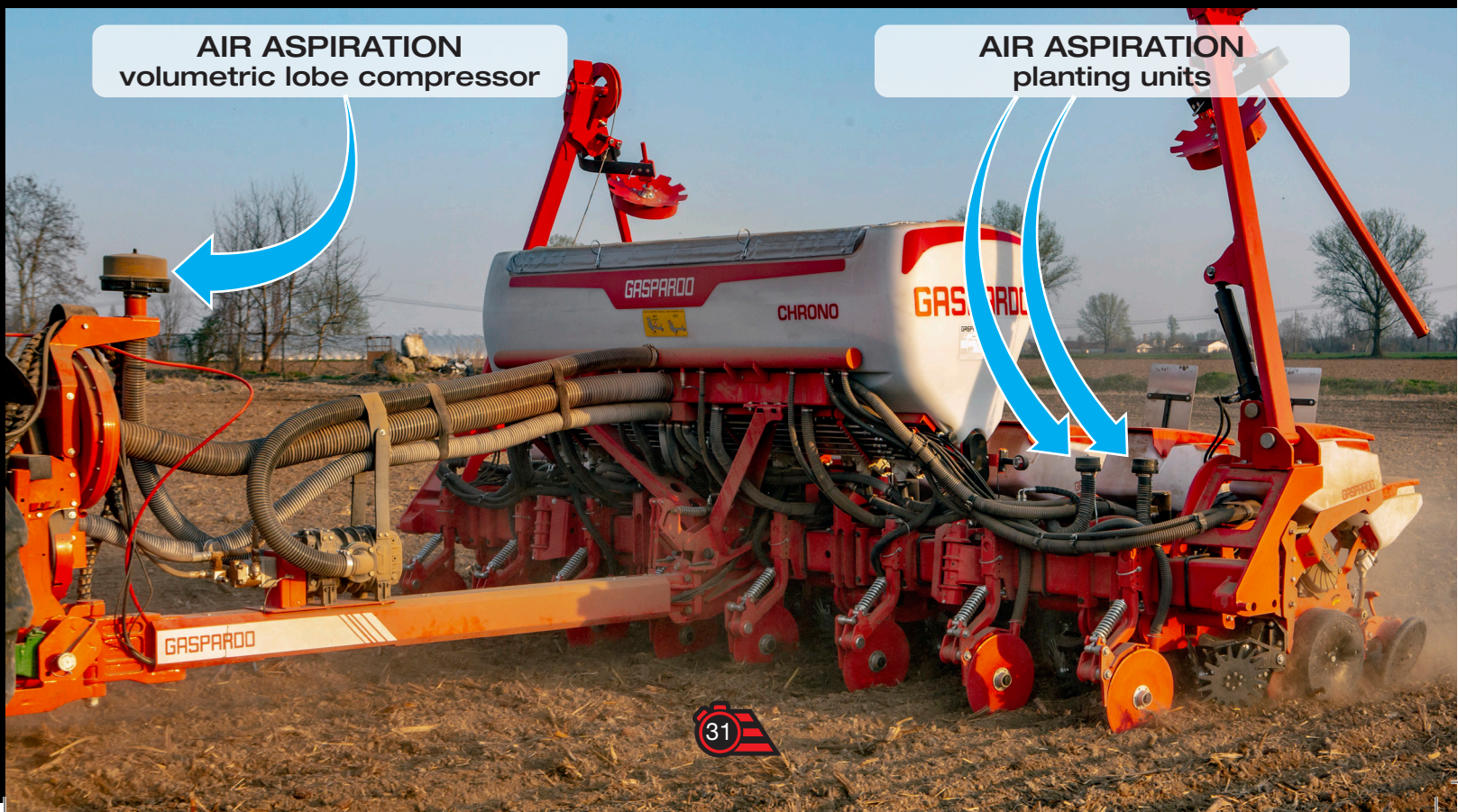

THE "MUST HAVE" ACCESSORY



TRASH WHEELS

Essential to clean the planting line from crop residue. It ensures uniform seeding depth.

DISC COULTER

In conditions of moist and tough soils, the notched front disc coulters (355 mm \varnothing) cut the soil surface and crop residue.

Its wavy profile improves cutting capability of residue.

ELECTRIC MICROGRANULATOR

The electric driven microgranulator allows for placing the pesticide or the starter fertilizer precisely close to the furrow.

The row by row shut-off ensures product savings and maximum yield.





SPOKE DEPTH WHEELS

The 3-spoke-depth wheels prevent terrain clogging between the wheels themselves and the disc coulters.

ON FIELD RESULTS

Through the monitor all the parameters of the seeding are controlled: failures, double seed drops and seeds spacing.



ISOBUS «GENIUS MASTER»

GENIUS MASTER facilitates the communication between CHRONO and the tractor thanks to the ISOBUS terminal: a single connection cable allows the control of all planting functions.



Universal connection cable



Compatibility with all MASCHIO GASPARDO ISOBUS equipment



Universal language shared with major tractor brands

Solutions for NON-ISOBUS tractors

GASPARDO provides the ISOBUS terminal and the cables to connect CHRONO with NON-ISOBUS tractors



TOUCH 800

- Seeding density adjustment
- Failures alerts
- Seeding data monitoring
- Precision farming
 - Automatic section control
 - Variable rate

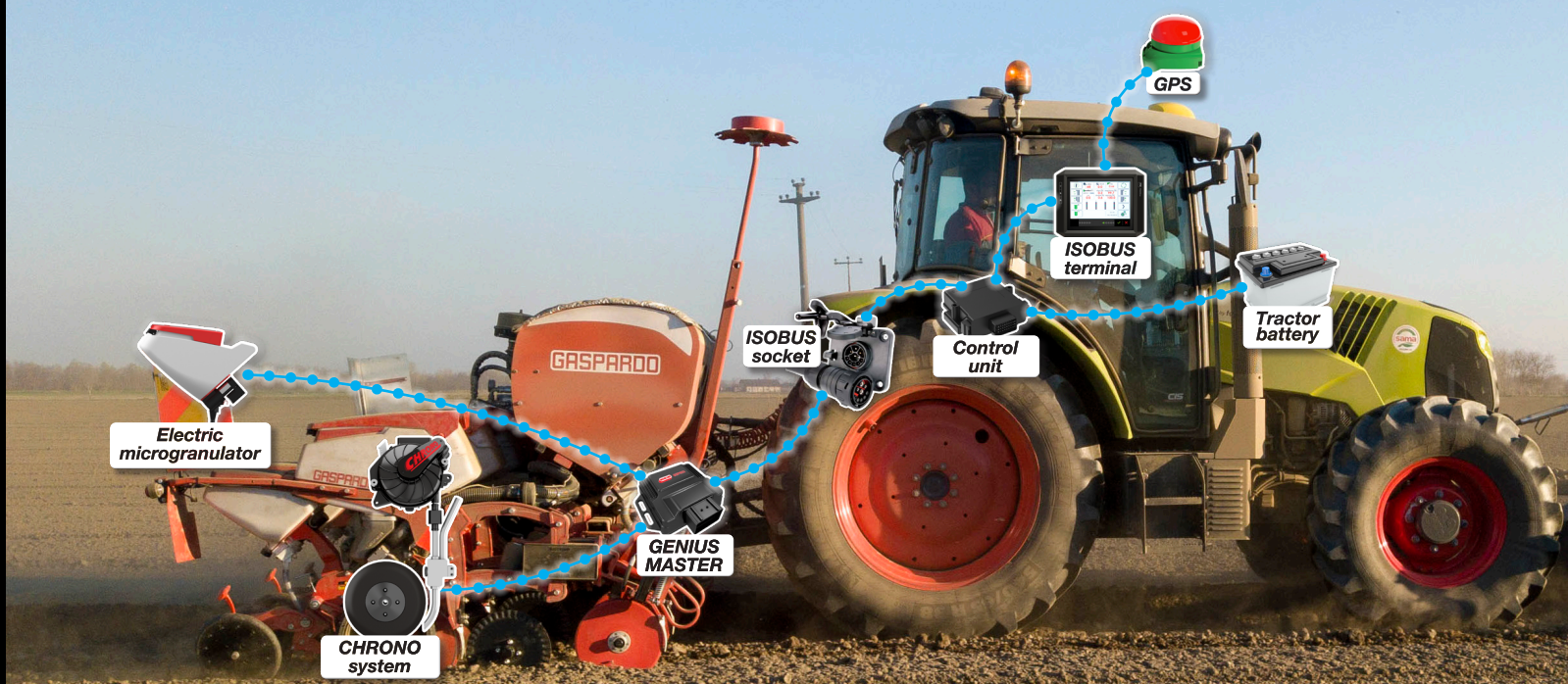

Electric microgranulator

CHRONO system

GENIUS MASTER

ISOBUS socket

Control unit

ISOBUS terminal

Tractor battery

GPS

CHRONO



Time is Money



AGRICOLTURA 4.0 with MG LIVE

From Precision Farming to Agriculture 4.0

Digital innovation plays a strategic role and it is greatly increasing the diffusion of high technology solutions in agriculture.

MG Live, available with GASPARDO seeders and planters, is a software to obtain, read and elaborate seeding data through a mobile connection. With MG Live the farmer has full control over his equipment.



MG Live!

MG Live grants remote access to the equipment. Not only can the farmer monitor the seeding in real time, but MASCHIO GASPARDO technicians are also able to check the correct functioning of the seeder.

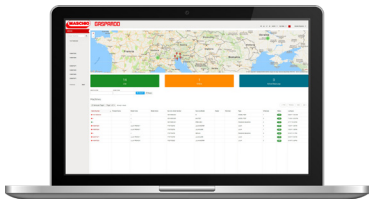

Your seeder under control

With MG Live and internet access the farmer remotely knows the geo location of the machine and the seeding performance.



Remote Service

MASCHIO GASPARDO service

GENIUS MASTER system receives updates directly from MASCHIO GASPARDO technical service.



Mobile Network

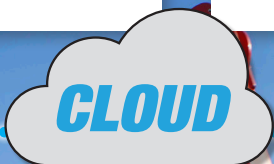

Mobile Network

ISOBUS terminal



MG-Live



GASPARDO

MASCHIO GASPARDO S.p.A.

Headquarters and production plant
Via Marcello, 73
I-35011 Campodarsego (PADOVA) - Italy
Tel. +39 049 9289810
info@maschio.com - www.maschio.com

Production plant

Via Mussons, 7
I-33075 Morsano al Tagliamento (PN) - Italy
Tel. +39 0434 695410

09-19 Cod. W00226802R

Maschio Gaspardo Marketing Dept.

Technical datas and models shown in this catalogue are not binding. We reserve the right to revise the contents of this catalogue, to amend or improve the specifications without notice.