

MASCHIO



**HAYMAKING
RANGE**

HAYMAKING RANGE





INDEX

Haymaking	4
Blade mowers	6
Drum mowers	8
Disc mowers	9
Conditioners	17
Rotary tedders	18
Rotary rakes	20

HAYMAKING

Production plant

Cremona - Italy

Total surface area: 33.000 m²
Covered area: 15.000 m²

MASCHIO Fienagione S.p.A. offers a full range of haymaking and harvesting attachments. These machines are internationally recognized for reliability and performance in all working conditions.

The range is divided into three product families:

- Cutting: double blade, drum, disc, side, front, trailed and combined mowers
- Harvesting: fixed or variable chamber and variable geometry round balers; square balers and shredding attachments
- Conditioning: rotary tedders and rotary rakes



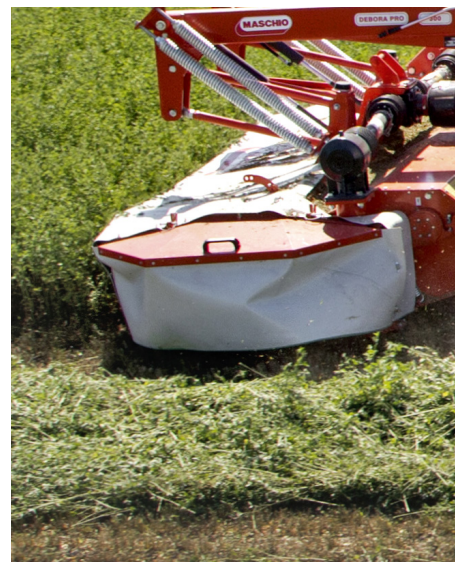

Blade mowers

FIORE 205

READY FOR EVERY OCCASION

FIORE is a proven reliability double blade mower. Light and versatile, it is ideal for the mowing of all crops, and particularly suitable for first mowing.

It is suitable both for the maintenance of domestic green zones as well as for professional use.

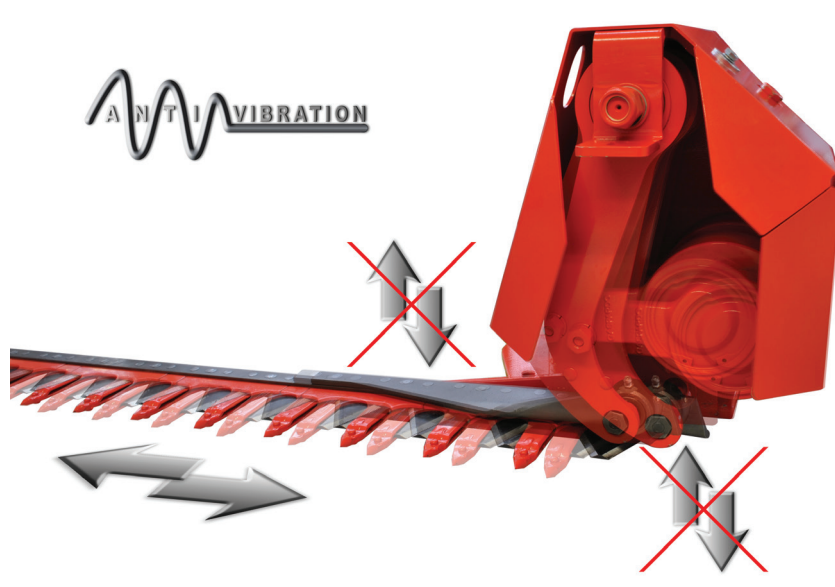

ANTI-VIBRATION SYSTEM

Kinematic mechanism fitted with vibration damping connecting rods able to absorb all vibrations and play. This feature prolongs the life of the cutting blades and of the connecting rods.

MODEL	Working width	PTO	Weight	Lifting	Anti-vibration device	Tractor power
	mt	rpm	kg			HP
FIORE	145-175-205	540	222-238	Mechanical	as standard	25-70
FIORE	145-175-205-235	540	222-246	Hydraulic	as standard	25-70



Hydraulic lifting

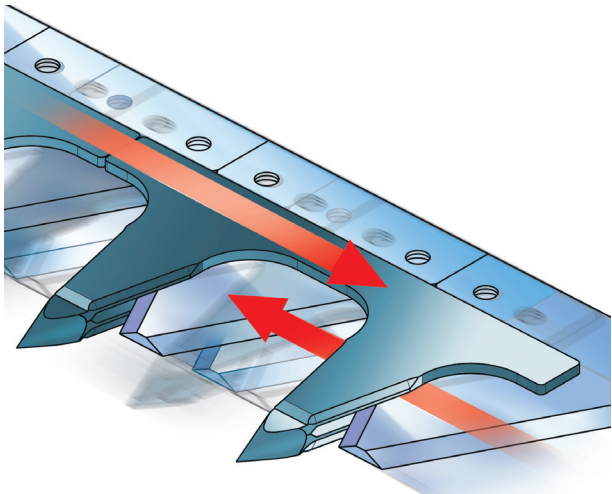

Patented blade tooth sliding



Mechanical lifting

Drum mowers

MASCHIO GASPARDO drum mowers ensure a high flow of fodder, while providing high cutting quality, without clogging, and a good working stability.

Quick-change blades

Inclined plate for maximum cutting quality, also with finned product

Self-lubricating bearings

Wear-resistant plate free-to-move

Cutting height adjustment through rings

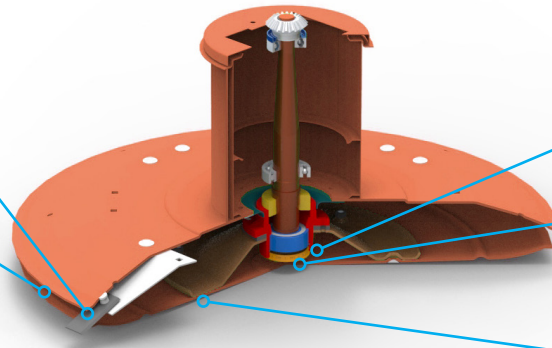

TIZIANA PRO

(Side mower)

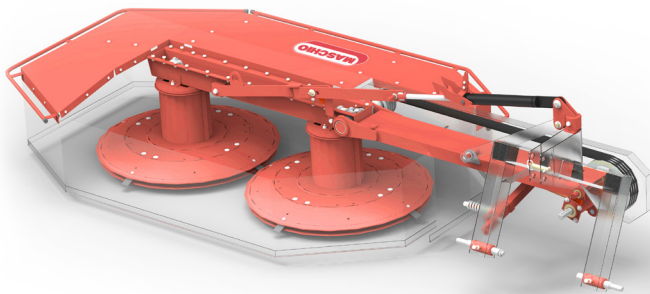

CHARACTERISTICS

- Side belts transmission
- Adaptation to the cutting surface
- Precise cutting height
- Hydraulic closure - HL Version
- Adjustable cutting height through rings
- Safety device for obstacles
- Quick-change blades
- 540 rpm PTO

MODEL	Working width	Drums	Blades	Tractor power	Weight
	mt	No.	No.	HP	kg
TIZIANA PRO 185	1,85	2	6	60	455
TIZIANA PRO 185 HL	1,85	2	6	60	460
TIZIANA PRO 210 HL	2,10	2	8	70	555

TIZIANA PRO F

(Front mower)

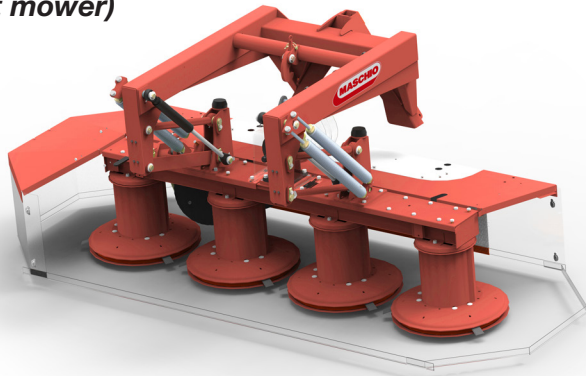

CHARACTERISTICS

- Excellent ground following on uneven conditions
- 3-point linkage cat. II
- Safety device for obstacles
- Mechanical transport lock
- Adjustable cutting height through rings
- CE Safety guards
- Foldable side guards for transport
- Spring suspension
- 1000 rpm PTO

MODEL	Working width	Swath width	Drums	Blades	Tractor power	Weight
	mt	mt	No.	No.	HP	kg
TIZIANA PRO F 265	2,65	1,20-1,60	4	12 (4x3)	80	780
TIZIANA PRO F 300	3,00	1,40-1,80	4	18 (2x5+2x4)	90	860

Disc mowers Lite CUT

LITECUT CUTTERBAR

Designed for small farms. Reliable, durable and precise cut with low power requirement.

Bolted cutter bar

Gears in oil bath

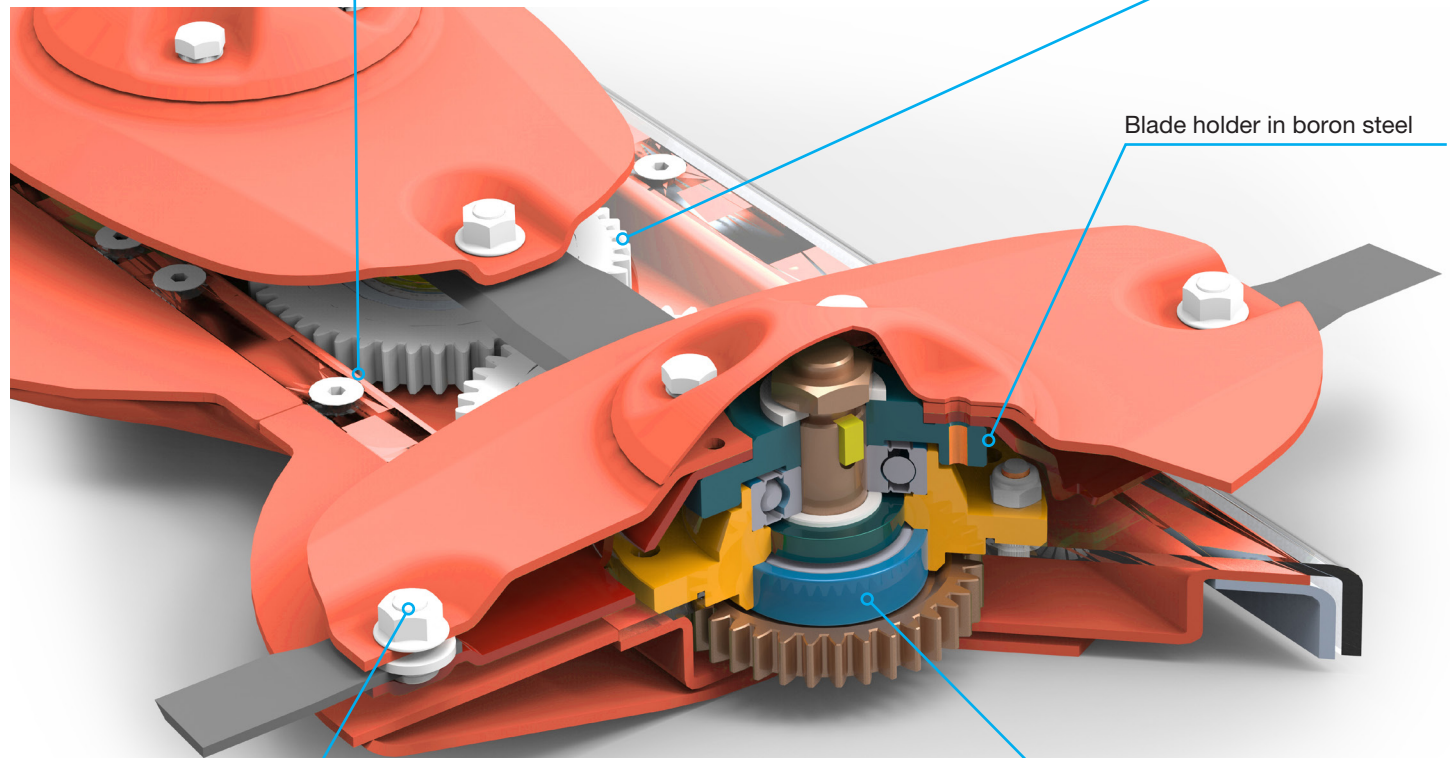

Innovative quick-change system of the blades

Toothed gears long life bearings

DEBORA

(Side mower)

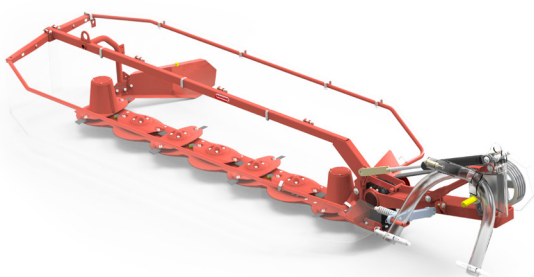

CHARACTERISTICS

- Equipped with LiteCut bar
- Cutting bar with quick-change system of the blades
- SafeGear safety system
- 3-point linkage cat. II
- Safety device for obstacles
- Blade replacement tool
- Hydraulic folding system
- Mechanical transport lock
- CE Safety guards

MODEL	Working width	Swath width	Discs	Blades	Tractor power	Weight
	mt	mt	No.	No.	HP	kg
DEBORA 160	1,60	1,10	4	8	20	410
DEBORA 200	2,00	1,40	5	10	30	445
DEBORA 240	2,40	1,70	6	12	45	490

Disc mowers PERFECT CUT

Focusing on professional users, we have developed the PerfectCut cutterbar. Key points are: cutting precision, high durability materials and SafeGear system to protect the cutterbar.

Hardened discs

- Smooth shape
- Crop flow and reduced workload stress
- High wear resistance

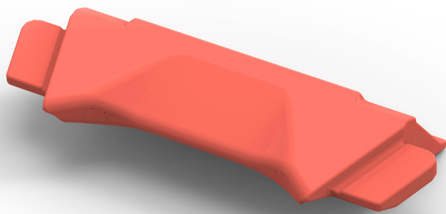

Welded profile

- Additional bar protection
- Replaceable

Blade supports

- Durable
- Easy to replace



Cutting blade

- High quality
- Quick-change system



Rear of the bar

- Perfectly smooth
- Interchangeable pads
- Reduced friction coefficient

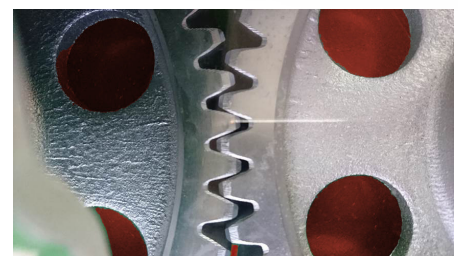
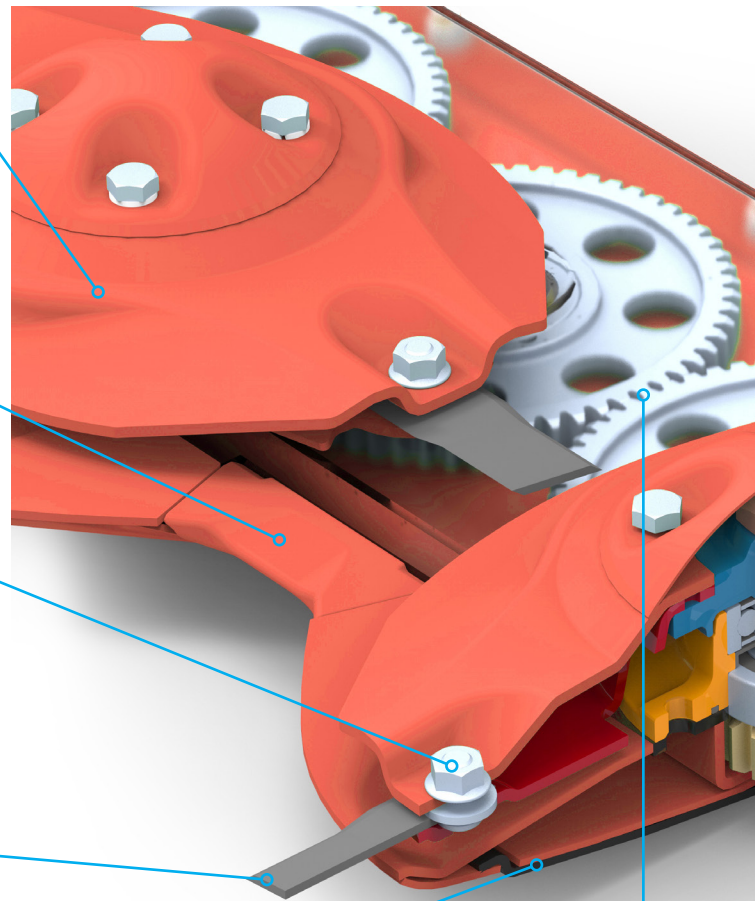

Gears

- 3 teeth always engaged
- Reduced wear
- Optimal power transmission

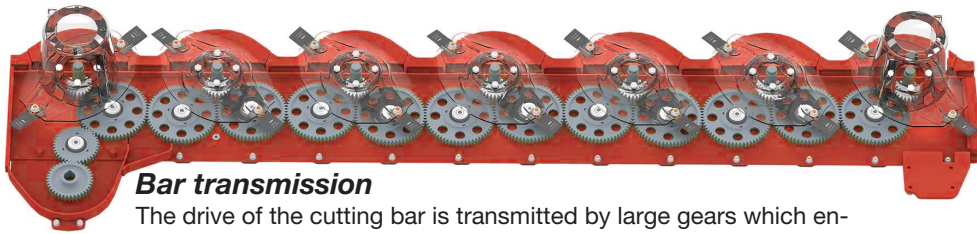

Bar transmission

The drive of the cutting bar is transmitted by large gears which ensure optimum transmission.

Replaceable safety key

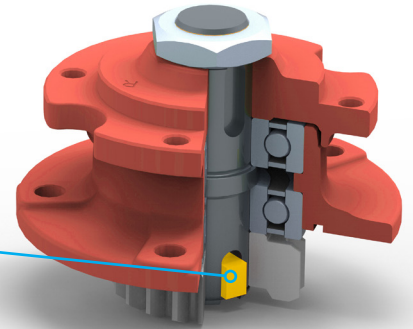

“SafeGear” safety system

- Replacement of the module without disassembling the cutterbar
- Gears inside the cutting bar
 - Sealed bearing
- Quick and easy to replace even in the field
 - Reusable after key replacement

Design

- Robust and durable
 - Fully welded
 - 6 mm thick steel

Free rotation of the blades

360°

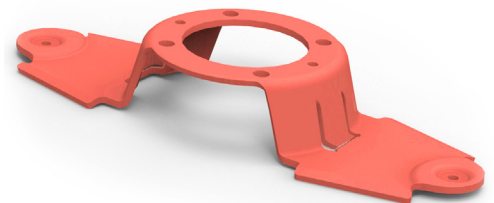

Central blade holder

- Resistant and high quality
 - High strength steel
 - Easy cleaning
 - 360° blade rotation

25 mm

21 mm



Gear thickness 25 mm

- Safety system
- High level of wear resistance
 - Optimum power transfer
 - Perfect 4 tooth assembly
 - Low noise

Optional slide

- Cutting height up to 12.5 cm
- Resistant steel
- Easy to mount

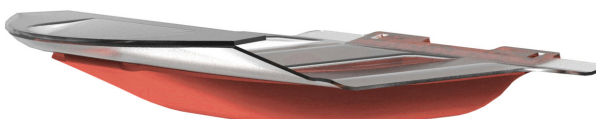

Disc mower with side suspension

DEBORA PRO 260 GM

DEBORA PRO

Lightweight and manoeuvrable, Debora Pro is the right choice for small farmers looking for a practical and low maintenance machine.

CHARACTERISTICS

- PERFECT CUT cutting bar with quick-change system of the blades
- SafeGear protection system
- 3-point linkage cat. II, cat. II-III for FL and GM
- Spring suspensions
- Rubber swath guides
- Mechanical safety device for obstacles
- Adjustable cutting height
- Blade replacement tool
- Hydraulic folding for transport
- Mechanical transport lock
- CE Safety guards
- Wear resistant slides
- Conditioner version: available with FL finger or roller GM conditioner

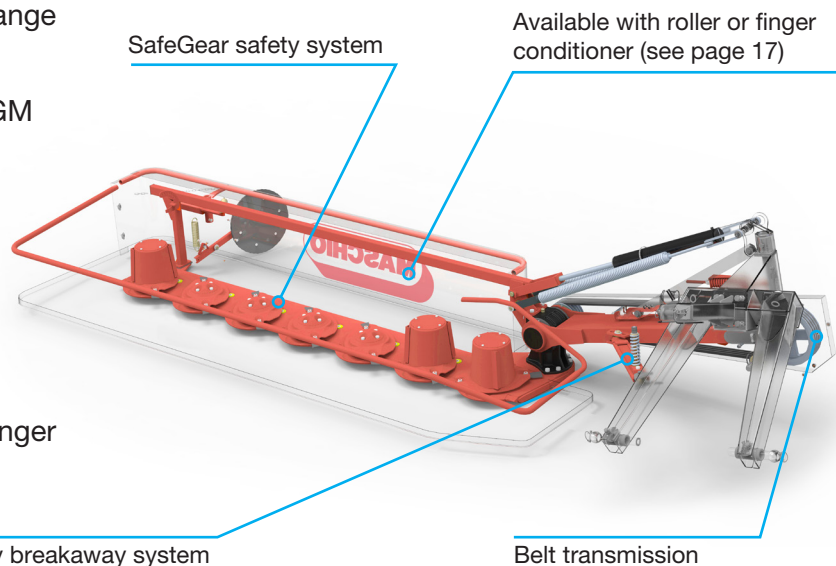

MODEL	Working width	Swath width	Discs	Blades	Tractor power	Weight
	mt	mt	No.	No.	HP	kg
DEBORA PRO 260	2,60	1,20-1,80	6	12	70	725
DEBORA PRO 300	3,00	1,30-1,90	7	14	80	785
DEBORA PRO 340	3,40	1,40-2,00	8	16	90	825
DEBORA PRO 260 FL	2,60	1,00-1,30	6	12	90	995
DEBORA PRO 220 GM	2,20	1,00-1,30	5	10	70	950
DEBORA PRO 260 GM	2,60	1,30-1,30	6	12	90	1005

Disc mower with central suspension

DEBORA PRO I

Debora Pro I ensures the maximum freedom of movement of the cutterbar, floating on the ground with great precision for a high cutting quality. Equipped with hydraulic safety system against obstacles.

CHARACTERISTICS

- PERFECT CUT cutting bar with quick-change system of the blades
- SafeGear protection system
- 3-point linkage cat. II, cat. II-III for FL and GM
- Rubber swath guides
- Hydraulic safety device for obstacles
- Adjustable working height
- Blade replacement tool
- Three transport positions available:
 - vertical side or vertical rear
 - Horizontal rear
- Mechanical transport lock
- CE Safety guards
- Conditioner version: available with FL finger or roller GM conditioner
- H version available, with spring suspension and side transport position

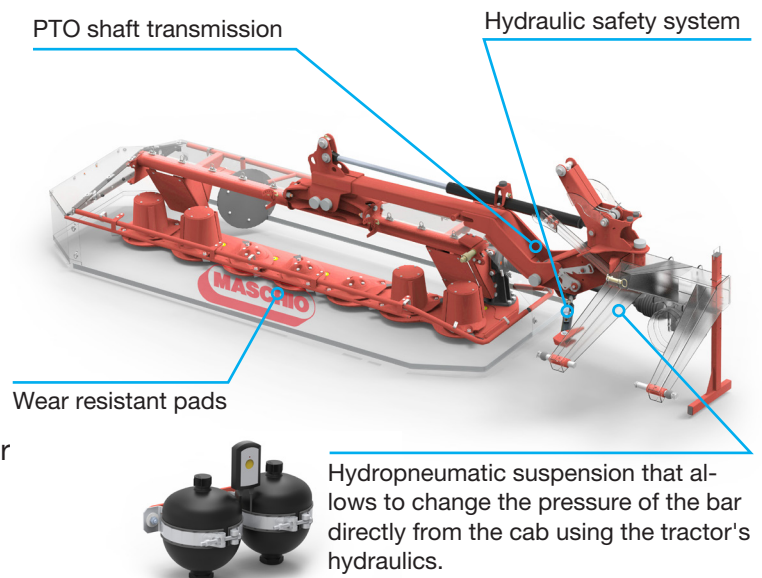

MODEL	Working width	Swath width	Discs	Blades	Tractor power	Weight
	mt	mt	No.	No.	HP	kg
DEBORA PRO I 260	2,60	1,50-1,90	6	12	70	1000
DEBORA PRO I 300	3,00	1,90-2,30	7	14	80	1060
DEBORA PRO I 340	3,40	2,30-2,80	8	16	90	1130
DEBORA PRO I 300 FL	3,00	1,40-1,70	7	14	90	1415
DEBORA PRO I 260 GM	2,60	1,00-1,30	6	12	90	1235
DEBORA PRO I 300 GM	3,00	1,90-2,30	7	14	80	1310

Front disc mower



DEBORA PRO F 300 GM

DEBORA PRO F

MASCHIO GASPARDO front mowers are an excellent solution for combination with mounted or semi-mounted machines, in order to achieve big areas with time and cost savings.

CHARACTERISTICS

- PERFECT CUT cutting bar with quick-change system of the blades
- SafeGear protection system
- 3-point linkage cat. II
- Spring suspension
- Wear resistant slides
- Rubber swath guides
- Safety device for obstacles
- Adjustable working height
- Blade replacement tool
- Mechanical transport lock
- CE Safety guards
- Conditioner version: available with FL finger or roller GM conditioner

Hydraulic lifting of the cutterbar

Spring suspension

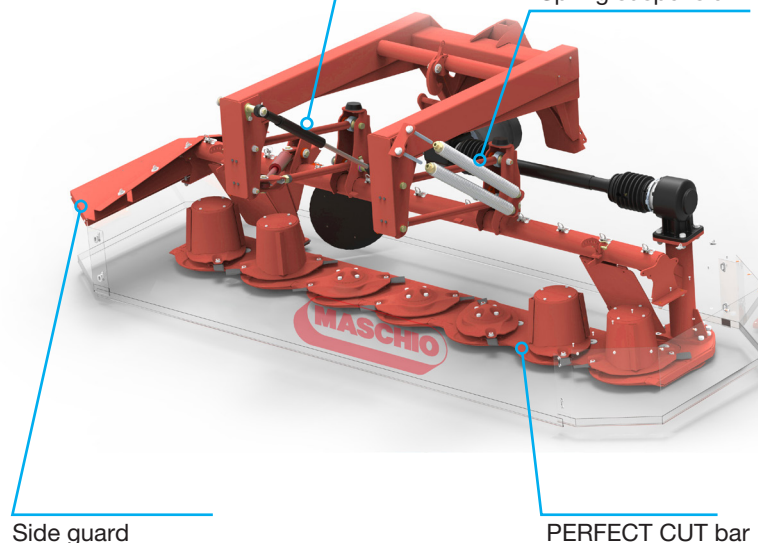

MODEL	Working width	Swath width	Discs	Blades	Tractor power	Weight
	mt	mt	No.	No.	HP	kg
DEBORA PRO F 300	3,00	1,30-1,50	7	14	80	940
DEBORA PRO F 340	3,40	1,70-1,80	8	16	90	1020
DEBORA PRO F 300 FL	3,00	1,40-1,70	7	14	100	1205
DEBORA PRO F 340 FL	3,40	1,40-1,80	8	16	110	1140
DEBORA PRO F 300 GM	3,00	1,40-1,70	7	14	100	1215

Semi-mounted disc mower

DEBORA PRO T 300 GM

DEBORA PRO T

The particular structure of our semi-mounted disc mowers with central drawbar, allows to work on both sides of the tractor. Through the independent lifting control it is possible to raise the cutter bar at the headlands without the need to turn off the PTO, reducing manoeuvring times.

CHARACTERISTICS

- PERFECT CUT cutting bar with quick-change system of the blades
- SafeGear protection system
- 2-point linkage cat. II
- Spring suspension
- Wear resistant slides
- Safety device for obstacles
- Adjustable working height
- Blade replacement tool
- CE Safety guards
- Conditioner version: available with FL finger or roller GM conditioner

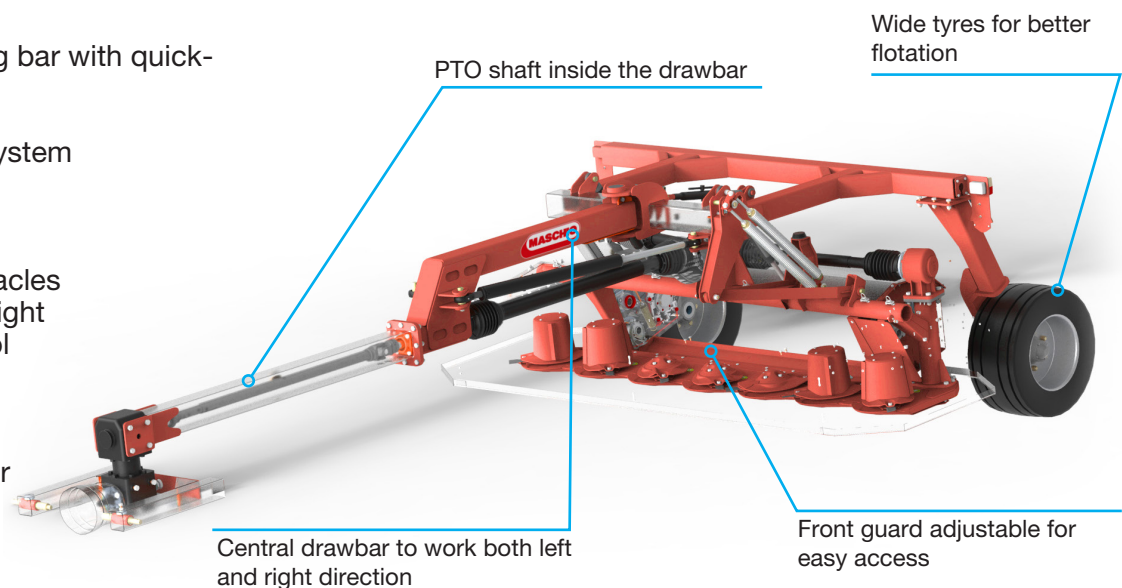

MODEL	Working width	Swath width	Discs	Blades	Tractor power	Weight
	mt	mt	No.	No.	HP	kg
DEBORA PRO T 300 FL	3,00	1,00-1,60	7	14	90	1910
DEBORA PRO T 340 FL	3,40	1,30-2,00	8	16	110	2095
DEBORA PRO T 300 GM	3,00	1,00-1,60	7	14	110	2100
DEBORA PRO T 300 FL NT	3,00	1,00-1,60	7	14	110	2160
DEBORA PRO T 340 FL NT	3,40	1,30-2,00	8	16	110	2345

Double-sided mower

DEBORA PRO COMBI

This type of machine has been designed for farmers who want to achieve maximum results in the minimum time. Thanks to its efficiency of approx. 10 ha/h and the low power demand, Debora Pro Combi is ideal for big farms and contractors looking for great value for money.

CHARACTERISTICS

- PERFECT CUT cutting bar with quick-change system of the blades
- SafeGear protection system
- 3-point linkage cat. II-III
- Wear resistant slides
- Rubber swath guides
- Hydraulic safety device for obstacles
- Adjustable working height
- Blade replacement tool
- Hydraulic folding for transport
- Hydropneumatic suspension



Hydropneumatic suspension as standard

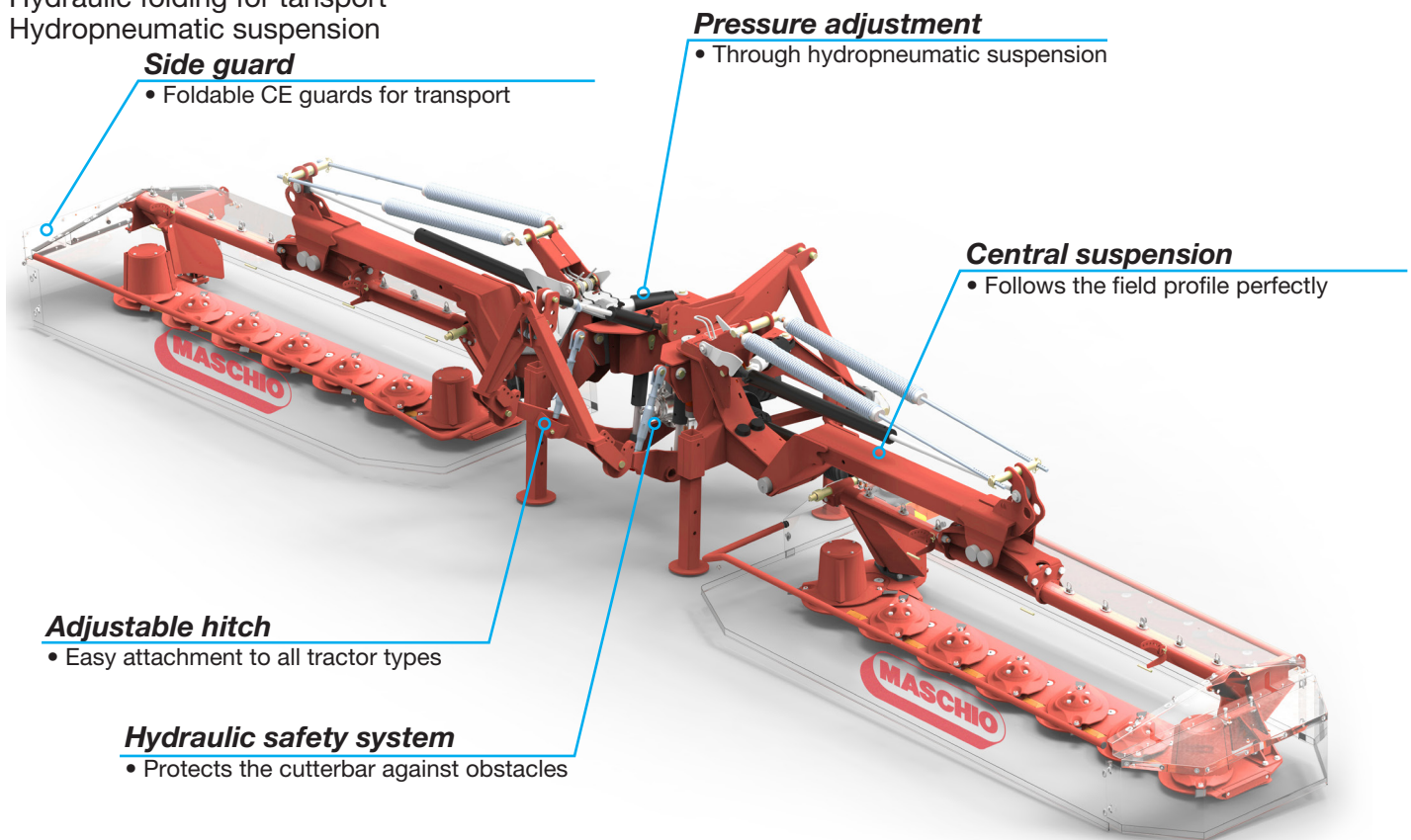

Side guard

- Foldable CE guards for transport

Pressure adjustment

- Through hydropneumatic suspension

Central suspension

- Follows the field profile perfectly

Adjustable hitch

- Easy attachment to all tractor types

Hydraulic safety system

- Protects the cutterbar against obstacles

MODEL	Working width	Swath width	Discs	Blades	Tractor power	Weight
	mt	mt	No.	No.	HP	kg
DEBORA PRO COMBI 861 I	8,6	1,90-2,30	14	28	130	2125
DEBORA PRO COMBI 941 I	9,4	2,30-2,70	16	32	140	2290
DEBORA PRO COMBI 861 I FL	8,6	1,90-2,30	14	28	130	2785
DEBORA PRO COMBI 941 I FL	9,4	2,30-2,70	16	32	140	2855
DEBORA PRO COMBI 861 I GM	8,6	1,90-2,30	14	28	130	2680
DEBORA PRO COMBI 941 I GM	9,4	2,30-2,70	16	32	140	2875

Conditioner range

GM and FL

Conditioning is the way to save time when drying the product in the field, but it is crucial to choose the right conditioner to get the best result in any situation. MASCHIO GASPARDO provides a rubber roller conditioner to take care of your leafy forage and a finger one to dry fast your product.

CONDITIONERS WITH RUBBER ROLLERS GM

Particularly suitable for the conditioning of alfalfa, clover and legumes.

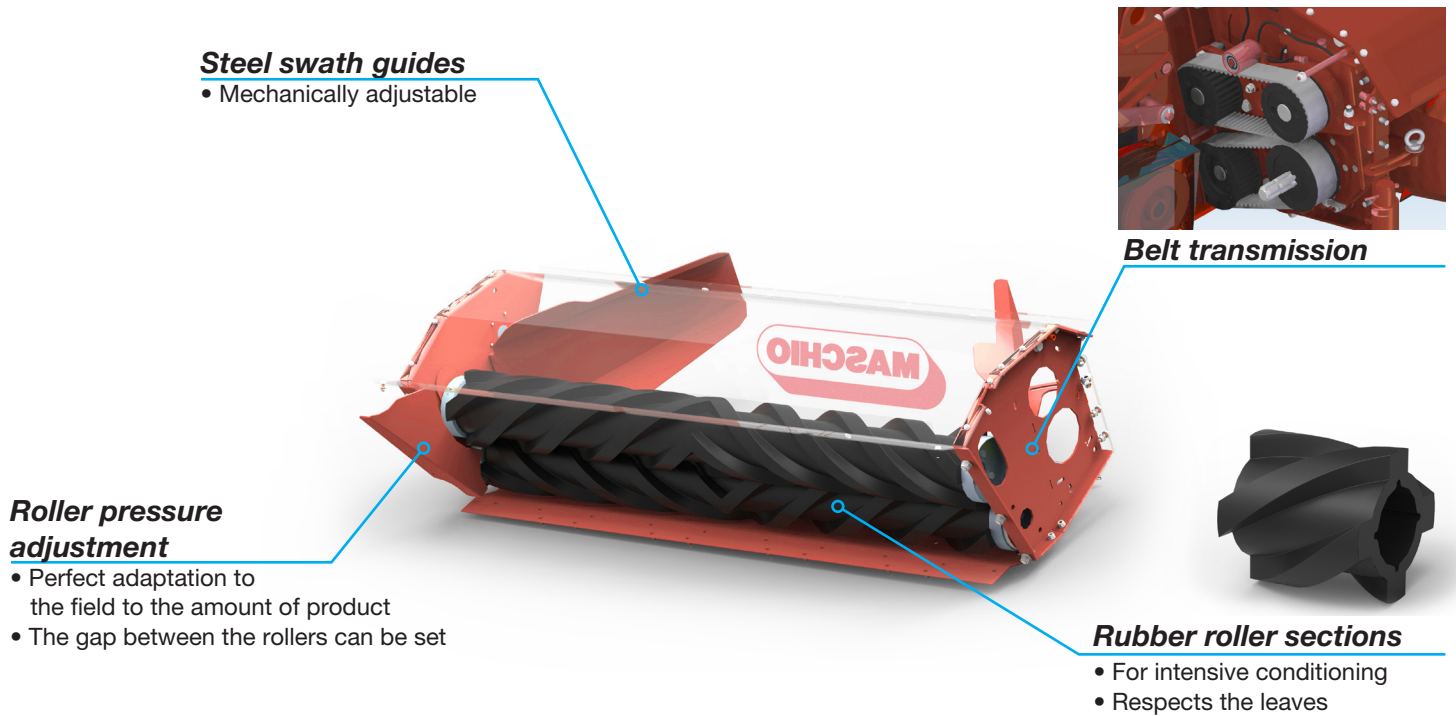

FINGER CONDITIONERS FL

Particularly suitable for the conditioning of grasses.

Deflector plate

- Defines the degree of conditioning

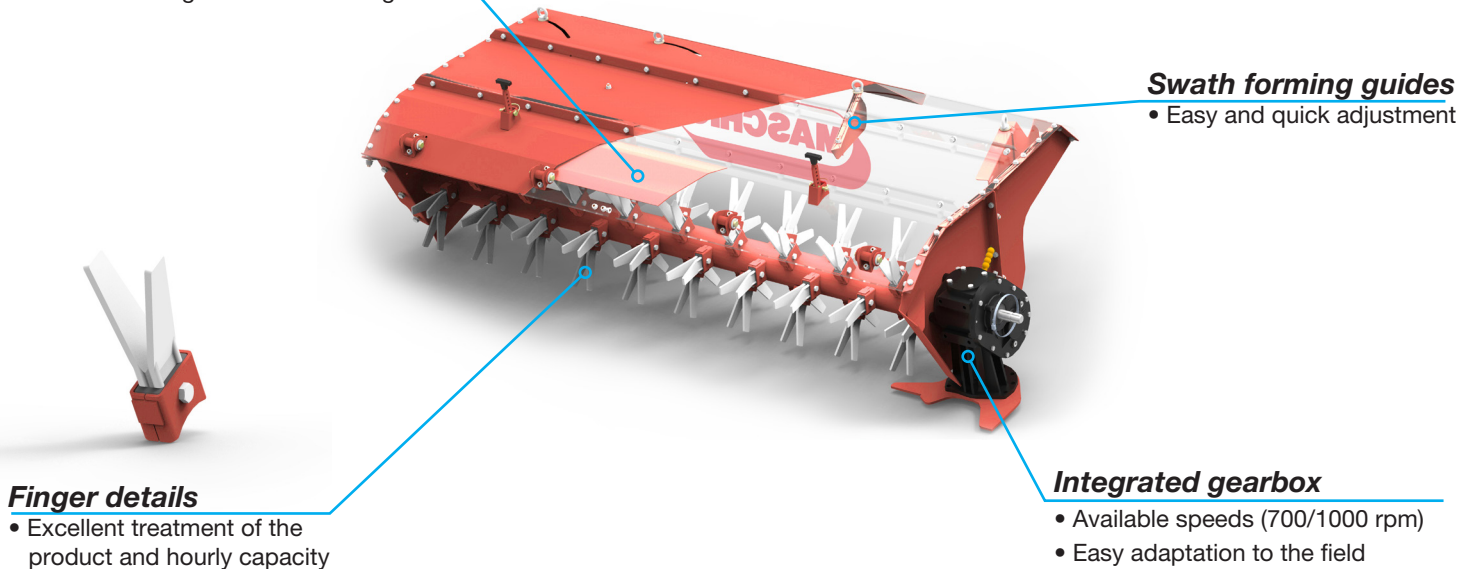

Rotary tedders

ELIA PRO 650

ELIA PRO

Perfect adaptation to the ground allows Elia Pro an optimal operation resulting in a smooth and clean forage distribution.

ELIA PRO 6 rotors

CHARACTERISTICS

- Oil bath gearbox
- Adjustable spreading angle
- Tilt mechanism for field border operations
- Wheels 16x6,5-8
- Hydraulic folding for transport
- Mechanical transport lock
- Lighting kit



Follows the contours of the ground with excellent spreading

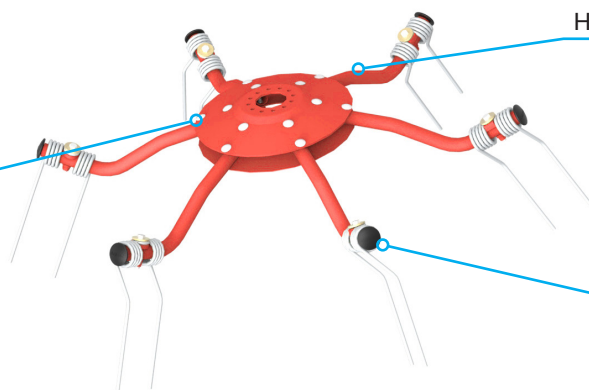

High resistance tubular profile arms

Protect against accidental release of the tines

MODEL	Working width mt	Transport width mt	Transport height mt	Rotors No.	Tractor power HP	Wheel dimensions	Weight kg
ELIA PRO 530	5,3	3	2,7	4	40	16x6,5-8	680
ELIA PRO 650	6,5	3	3,6	6	50	16x6,5-8	915
ELIA PRO 770	7,7	2,8	4	6	60	16x6,5-8	945



ELIA PRO 4 rotors



Cardan joint
Easy access to greasing points.
Ensures constant power to the rotors.



Wheels
The wheels have a protective casing which prevents clogging.

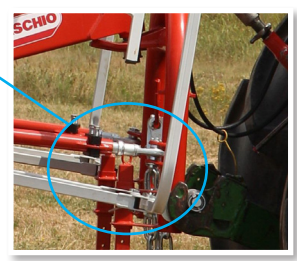

Damping arms
The suspension allows the machine to remain central during lifting.



TRANSPORT POSITION
The arms are raised in the transport position by means of two hydraulic cylinders. Two automatic safety interlocks fasten them giving the machine excellent stability, ensuring safe transport without risks.



Rotary rakes

GOLIA PRO 300

GOLIA PRO

Golia Pro is a single rotary rake ideal for small tractors. The turning hitch and the tandem chassis make it suitable for all types of terrain.

CHARACTERISTICS

- 3-point linkage cat. II
- Tandem chassis as standard for versions 410-440-470
- Front support wheel as standard for version 470
- Lighting kit as standard for version 440-470
- Oil bath gear box lubrication (version 470 grease bath)
- Mechanical adjustment of the windrow width
- Adjustable working height
- Removable arms for transport
- Mechanical folding of the windrow curtain
- Version ST: turning hitch
- Version T: trailed

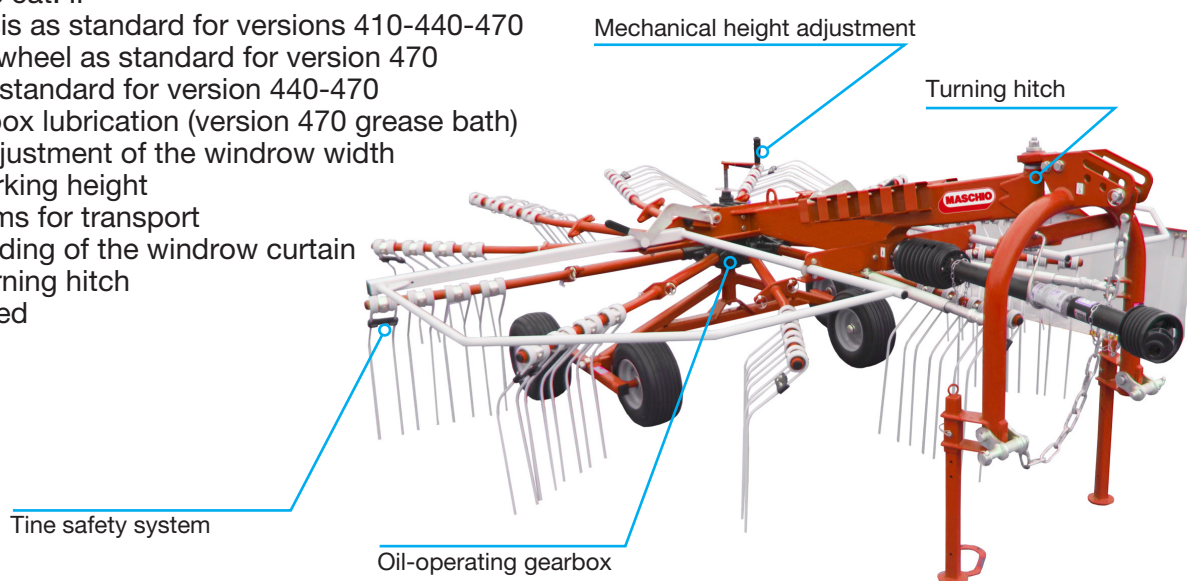

MODEL	Working width	Transport width	Swath width	Arms	Tractor power	Wheel dimensions	Weight
	mt	mt	mt	No.	HP		kg
GOLIA PRO 300 / ST	3,00	1,50	0,80-1,50	8	20	15x6-6	310
GOLIA PRO 350 / ST	3,50	1,51	0,80-1,50	9	25	15x6-6	340
GOILA PRO 410	4,10	1,90	0,80-1,50	11	40	16x6,5-8	590
GOILA PRO 440	4,40	2,10	0,80-1,50	11	45	16x6,5-8	740
GOILA PRO 470	4,70	2,30	0,80-1,50	13	50	16x6,5-8	820
GOLIA PRO 410 T	4,10	1,80	0,80-1,50	11	35	16x6,5-8	740
GOLIA PRO 470 T	4,70	2,35	0,80-1,50	13	45	18x8,5-8	890



GOLIA PRO 2C

Designed to reduce harvesting times for large farms, Golia Pro 2C has an adjustable working capacity from 7.2 to 7.8 m. Rotors equipped with six wheels allow a precise ground following.

CHARACTERISTICS

- 2-point linkage cat. II
- Hydraulic folding rotors
- Oil bath gearbox
- Hydraulic adjustment of the windrow width
 - standard for version 840
 - optional for version 780
- Mechanical adjustment of the working height
- Windrow curtain
- Tandem chassis
- Rear steering wheels
- Removable arms for transport
- Mechanical transport lock
- Lighting kit

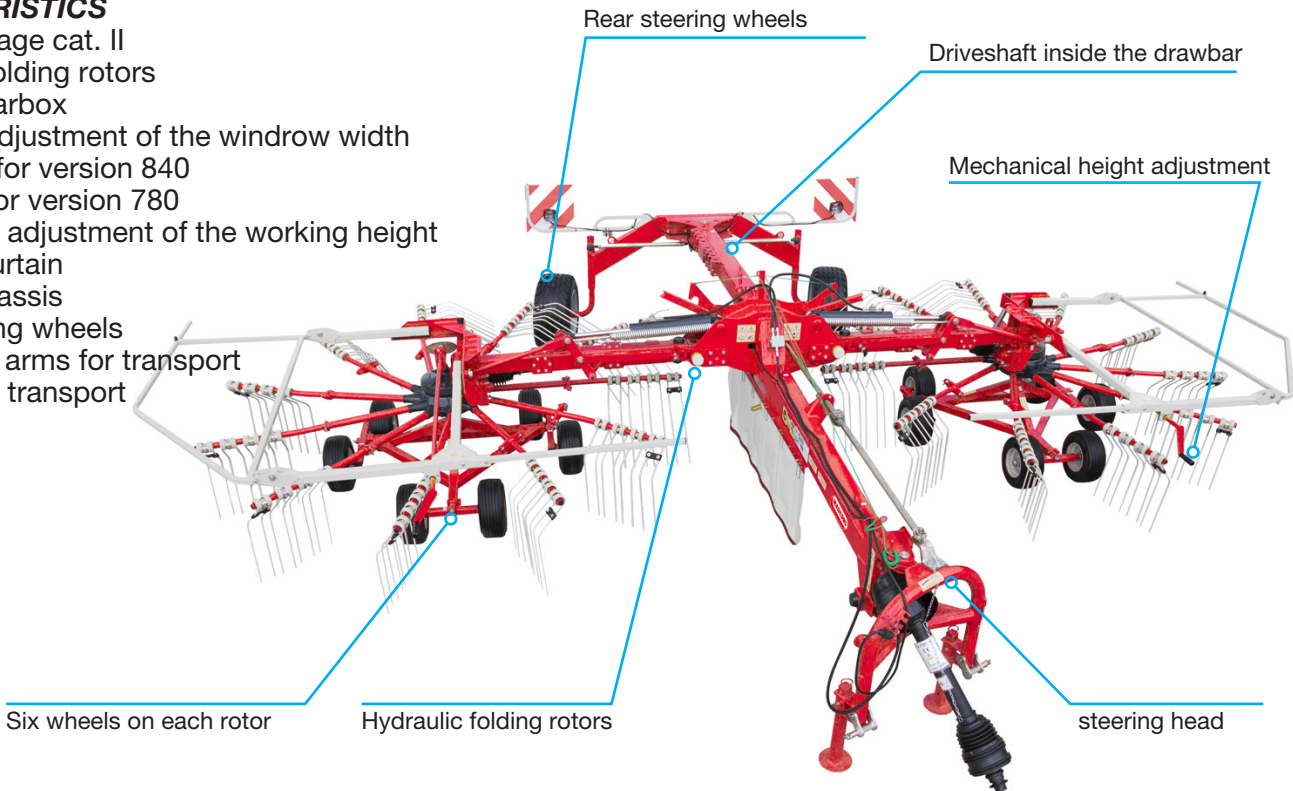

MODEL	Working width	Transport width	Transport length	Transport height	Swath width	Tractor power	Wheel dimensions	Weight
	mt	mt	mt	mt	mt	HP		kg
GOLIA PRO 2 C 780	7,2-7,8	2,90	5,5	3,4	1X(1,50/2,00)	60	16x6,5-8	2040
GOLIA PRO 2 C 840	7,6-8,4	2,95	6,0	3,7	1X(1,50/2,00)	80	16x6,5-8	2330



GOLIA PRO 2 680

GOLIA PRO 2

Thanks to the second hydraulically adjustable rotor, it is possible to create both two separate windrows in the event of large amounts of product, as well as a single lateral swath. With this kind of machine the product is completely turned and fast dried.

CHARACTERISTICS

- 2-point linkage cat. II
- Hydraulic lifting of the rotors in sequence for headland manoeuvres
- Oil bath gearbox
- Adjustable swath width
- Rotors aligned under the frame in transport position
- Adjustable working height
- Windrow distribution on the left side of the tractor
- Mechanical folding of the windrow curtain
- Support wheel as standard
- Tandem chassis
- Removable arms for transport
- Lighting kit

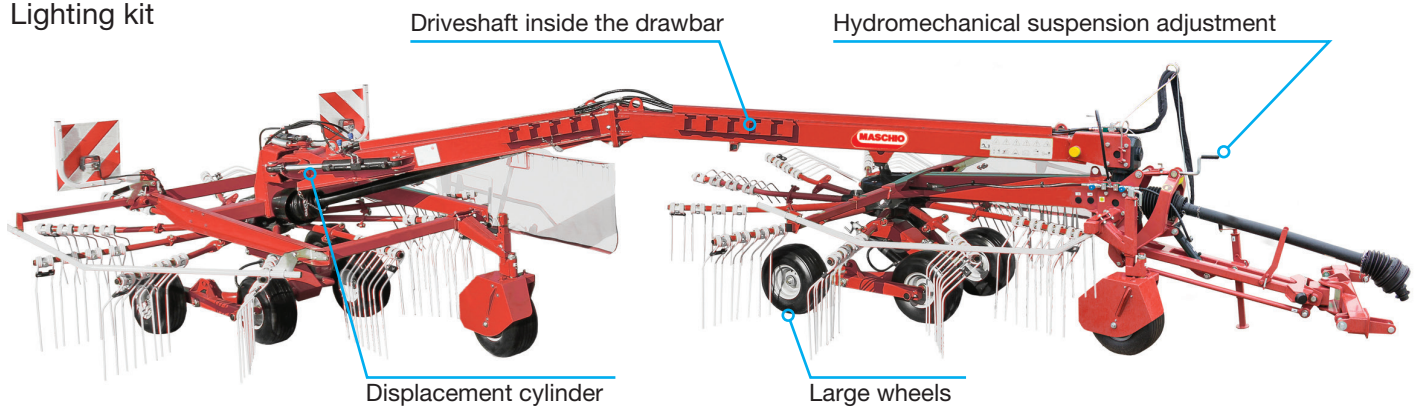
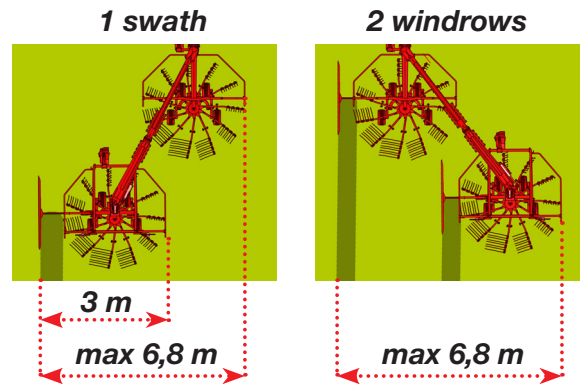

MODEL	Working width mt	Transport width mt	Transport length mt	Swath width mt	Tractor power HP	Wheel dimensions	Weight kg
GOILA PRO 2 680	3,40-6,80	1,8-3,0	8,40	2X(0,80/1,50) - 1X(1,0/2,5)	60	18x8,5-8	1720



GOLIA PRO 2H

High performance for the Golia Pro 2H version which can create both one or two windrows even with big amounts of product. The frame drawn with two steering wheels follows the tractor without running over the windrow.

CHARACTERISTICS

- 2-point linkage cat. II
- Hydraulic rotor lifting
- Oil bath gearbox
- Vertical folding for transport
- Hydraulically adjustable swath width
- Adjustable working height
- Windrow distribution on the left right of the tractor
- Tandem chassis
- Rear steering wheels
- Removable arms for transport
- Lighting kit

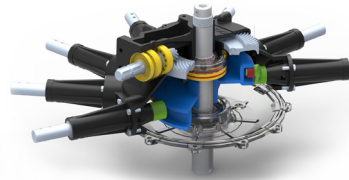

High quality rotor, oil bath transmission, maintenance free. The tangential arrangement of the arms improves raking and optimal swath formation.

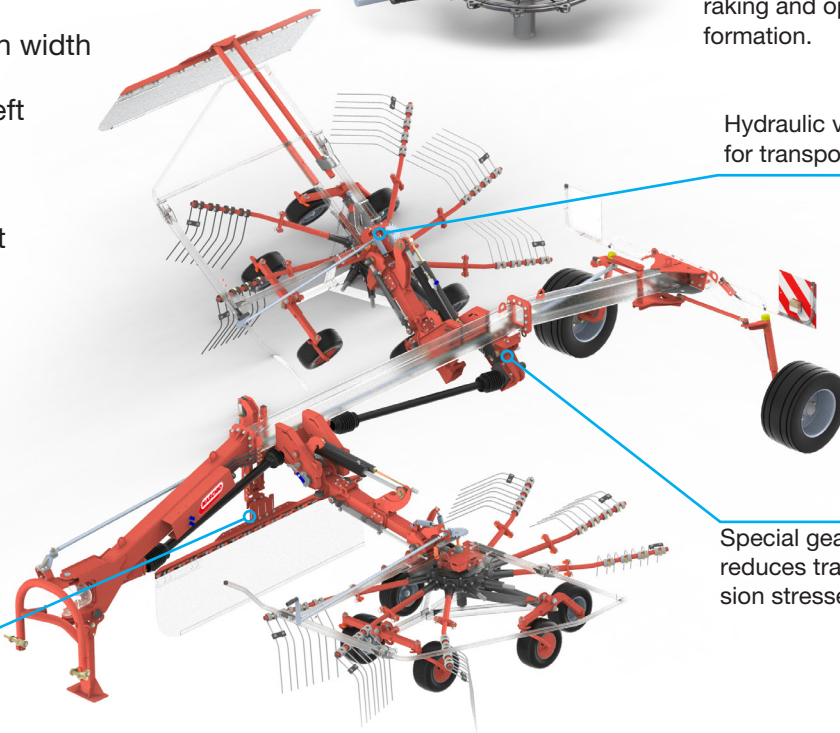

Hydraulic vertical folding for transport

Special gearbox reduces transmission stresses

Hydraulic lifting of the windrow curtain

MODEL	Working width mt	Transport width mt	Swathee width mt	Tractor power HP	Wheel dimensions	Weight kg
GOLIA PRO 2 H 730	6,70-7,30	3,0	2X(0,80/1,50)	60	16x6,5-8	2450



MASCHIO Fienagione S.p.A.

Headquarters and production plant
Via Bredina 6

I-26100 CREMONA (CR) - Italy

Tel. +39 0372 564610 - Fax +39 0372 564625
info@maschio.com - www.maschio.com

MASCHIO GASPARDO S.p.A.

Via Marcello, 73

I-35011 Campodarsego (PADOVA) - Italy

Tel. +39 049 9289810 - Fax +39 049 9289900
info@maschio.com - www.maschio.com

10-17 Cod. W00226438R
MASCHIO GASPARDO Marketing Dept.

For graphic reasons, some pictures and images do not show the "EC" safety guards. Technical datas and models shown in this catalogue are not binding. We reserve the right to revise the contents of this catalogue, to amend or improve the specifications without notice.